

VALVES FOR DRY OR LUBRICATED AIR, NEUTRAL GASES AND LIQUIDS



3/2

Actuation	Body	Function	Port Size	Orifice (mm)	Flow Factor Kv(l/min)	MOPD (bar)	Max Fluid Temp. (°C)	Page Parker Valves	Page Parker LUCIFER® Valves			
Direct Operated	Brass/Pipe mounting	Normally Closed	1/8"	1.2 to 2.5	3.5	20	140	208				
			1/8"-1/4"	2.5	3.5	7	75	-	210			
			1/4"	1 to 4.5	7	30	140	208				
		Normally Open	1/4"	1.5 to 3	4.5	16	120	-	218			
			Universal	1/8"	1.5 to 2.5	3.5	10	140	220			
				1/4"	0.8 to 3.5	5	30	140	220			
	Brass/Sub-base mounting	Control by Electric Impulse	Normally Closed	1/4"	1.5	1.5	16	100	-	224		
				SB	1.3	1	20	140	226			
				3.5 mm	1.2 to 1.5	0.9	10	75	-	228		
		Normally Open	5 mm	1 to 2.5	3.5	16	120	-	228			
			Universal	5 mm	1.5 to 2.5	2.2	15	120	-	230		
				1/8"-1/5"	1.5	1.5	10	120	-	232		
Anodized aluminium/Banjo 303 Stainless St./Sub-base mounting POM/Sub-base mounting	Normally Closed	Normally Closed	1/8"	1.2	-	10	50	-	234			
			5 mm	1.5	1.5	15	100	-	236			
	Normally Closed	Normally Closed	3 mm	2	2	10	50	-	238			
			Pilot Operated	Anodized aluminium/Pipe mounting	Normally Closed	1/4"	6.5 to 8	20	15	75	-	240
						1/2"	14	-	15	75	-	242
					Normally Open	1/4"	8	20	40	75	-	242
1/2"	14	-	15	100		-	244					
Anodized aluminium/Sub-base mounting/Poppet	Normally Closed	Normally Closed	1/2"	15	-	10	75	-	244			

3/2

VALVES FOR DRY OR LUBRICATED AIR, NEUTRAL GASES AND LIQUIDS
DIRECT OPERATED



Industrial Equipment



Commercial Equipment



Process

BRASS PIPE MOUNTING

NORMALLY CLOSED

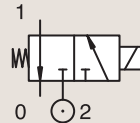

Port size	Orifice Ø		Flow factors			Operating Pressure Differential			Fluid Temp.		Seat Seal	Parker Valves			Power		Coil Group	Dwg. No.	
	1	(2)	1	(2)	1	(2)	Min	Max(MOPD)	Min	Max		Valve Order Number	Valve Type	Coil Type	AC W	DC W			
BSP	mm		Kv l/min		KV l/min		bar	AC bar	DC bar	°C	°C								
1/8"	1.2	1.6	0.7	-	0.04	-	0	8	-	-10	140	FKM	398102 ₁	N79.4IV	WB4.5 115/50-60	4.5	-	1.3	066
	1.2	1.6	0.7	-	0.04	-	0	14	-	-10	140	FKM	398104 ₁	N79.4IV	WB4.5 230/50-60	4.5	-	1.3	066
	1.2	1.6	0.7	-	0.04	-	0	14	-	-10	140	FKM	398120 ₁	N79.4IV	WB4.5 24/50-60	4.5	-	1.3	066
	1.2	1.6	0.7	-	0.04	-	0	14	-	-10	140	FKM	398100 ₁	N79.4IV	WB4.5 42/50-60	4.5	-	1.3	066
	1.5	1.6	1	-	0.06	-	0	8	-	-10	140	FKM	398112 ₁	N79.4AV	WB4.5 230/50-60	4.5	-	1.3	066
	1.5	1.6	1	-	0.06	-	0	8	-	-10	140	FKM	398122 ₁	N79.4AV	WB4.5 24/50-60	4.5	-	1.3	066
	1.5	1.6	1	-	0.06	-	0	8	-	-10	140	FKM	398138 ₁	N79.6AV	WB4.5 115/50-60	4.5	-	1.3	080
	1.5	1.6	1	-	0.06	-	0	8	-	-10	140	FKM	398130U ₁	N79.6AV	WB4.5 115/60	4.5	-	1.3	080
	1.5	1.6	1	-	0.06	-	0	8	-	-10	140	FKM	398114 ₁	N79.6AV	WB4.5 230/50-60	4.5	-	1.3	080
	1.5	1.6	1	-	0.06	-	0	8	-	-10	140	FKM	398142 ₁	N79.6AV	WB4.5 240/50-60	4.5	-	1.3	080
	1.5	1.5	1.2	-	0.07	-	0	20	-	-10	140	FKM	362560J	PM141AV	ZB09	9	-	20.1/20.2	029
	2	1.6	1.5	-	0.09	-	0	5	-	-10	140	FKM	398134U ₁	N79.6BV	WB4.5 115/60	4.5	-	1.3	080
	2	1.6	1.5	-	0.09	-	0	5	-	-10	140	FKM	398136U ₁	N79.6BV	WB4.5 208-240/60	4.5	-	1.3	080
	2	1.6	1.5	-	0.09	-	0	5	-	-10	140	FKM	398132 ₁	N79.6BV	WB4.5 230/50-60	4.5	-	1.3	080
2	2.5	2	-	0.12	-	0	15	-	-10	140	FKM	362570J	PM141BV	ZB09	9	-	20.1/20.2	029	
1/4"	2	2.5	2	-	0.12	-	0	15	-	-10	140	FKM	362620J	PM141FV	ZB09	9	-	20.1/20.2	033
	2.5	2.5	2.8	-	0.17	-	0	9	-	-10	140	FKM	362630J	PM141GV	ZB09	9	-	20.1/20.2	033

Notes:

1. Ordering number is for an assembled valve and coil, with the voltage shown.



For this page	Port size	Orifice (mm)	Kv (l/min)	MOPD (bar)	Fluid Temp (°C)	Amb Temp (°C)
From	1/8"	1.2	0.7	5	-10	-10
To	1/4"	2.5	2.8	20	140	50

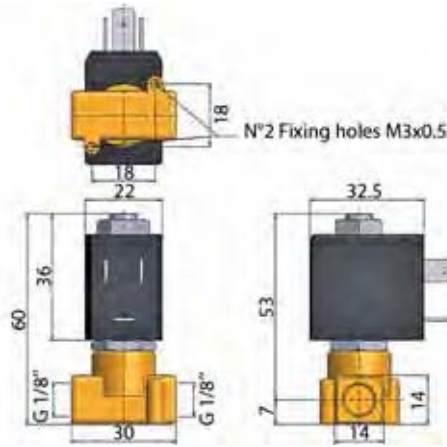

Drawing 066



Drawing 080

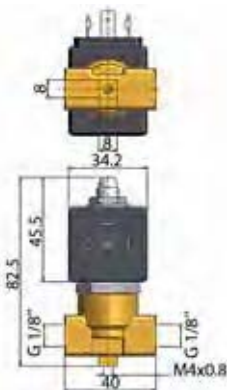

Drawing 029

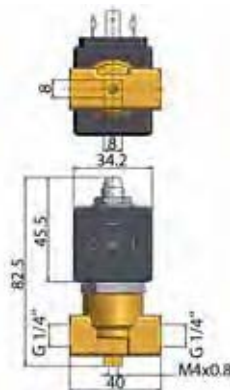

Drawing 033

3/2

VALVES FOR DRY OR LUBRICATED AIR, NEUTRAL GASES AND LIQUIDS
DIRECT OPERATED

BRASS

PIPE MOUNTING

NORMALLY CLOSED

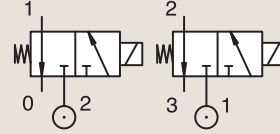

Port size	Orifice Ø		Flow factors			Operating Pressure Differential			Fluid Temp.		Seat Seal	Parker LUCIFER® Valves			IS	Power		Coil Group	Dwg. No.	
	1	(2)	1	(2)	1	(2)	Min	Max (MOPD)		Min		Max	Valve Ref.	Housing Ref.		Coil Ref.	AC W			DC W
	mm		Kv l/min		KV l/min		bar	AC bar	DC bar	°C		°C								
1/8"	1.2	1.5	0.7	0.9	0.04	0.05	0	10	10	-10	75	FKM	131M15	8993	488980	2	2.5	1.1	3382	
	1.5	1.5	0.9	0.9	0.05	0.05	0	7	7	-10	75	FKM	131M14	8993	488980	2	2.5	1.1	3382	
	1.5	1.5	1.5	1.5	0.09	0.09	0	15	15	-10	120	FKM	E131K14	4270	481000	8	8	2.1	3510	
	1.5	1.5	1.5	1.5	0.09	0.09	0	15	15	-10	100	FKM	E131K14	2995	481865	8	9	2.1	3510	
	2	2.5	2.5	3.5	0.15	0.21	0	10	10	-10	120	FKM	131K16	4270	481000	8	8	2.1	3510	
	2	2.5	2.5	3.5	0.15	0.21	0	10	10	-10	100	FKM	131K16	2995	481865	8	9	2.1	3510	
	2	2.5	2.5	3.5	0.15	0.21	0	10	10	-10	120	FKM	131K1650 ₁	4270	481000	8	8	2.1	3510	
	2	2.5	2.5	3.5	0.15	0.21	0	10	10	-10	100	FKM	131K1650 ₁	2995	481865	8	9	2.1	3510	
	2.5	2.5	3.5	3.5	0.21	0.21	0	7	7	-10	120	FKM	E131K13	4270	481000	8	8	2.0	3510	
	2.5	2.5	3.5	3.5	0.21	0.21	0	7	7	-10	100	FKM	E131K13	2995	481865	8	9	2.0	3510	
1/8"-1/4"	2.5	2.5	3	3	0.18	0.18	0	-	2	-20	75	PUR	131K0397	2995	482740	-	1.6	6.0/8.0	8023	
	2.5	2.5	3	3	0.18	0.18	0	2	2	-20	75	PUR	131K0397	-	495900	2.5	2	6.0/8.0	8023	
	2.5	2.5	3	3	0.18	0.18	0	-	2	-20	75	PUR	131K0397	-	495910	*	-	0.3 to 3	6.0/8.0	8023
	2.5	2.5	3.5	3.5	0.21	0.21	0	7	7	-40	75	PUR	E131K0358 ₁	4270	481000	8	8	2.1	3510	
	2.5	2.5	3.5	3.5	0.21	0.21	0	7	7	-40	75	PUR	E131K0358 ₁	2995	481865	8	9	2.1	3510	
1/4"	1	1	0.6	0.6	0.03	0.03	0	-	10	-10	55	FKM	131K0490	2995	483580.01	*	-	0.5 to 3	7.0/8.0	7058
	1	1	0.6	0.6	0.03	0.03	0	-	10	-10	75	FKM	131K0490	-	488660.01	*	-	0.3 to 3	7.0/8.0	7058
	1	1	0.6	-	0.03	-	0	-	10	-10	75	FKM	131K0490	-	495910	*	-	0.3 to 3	7.0/8.0	7058

Notes:

1. With manual override

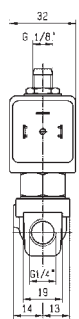
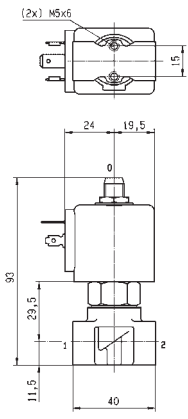

Drawing 7058



For this page	Port size	Orifice (mm)	Kv (l/min)	MOPD (bar)	Fluid Temp (°C)	Amb Temp (°C)
From	1/8"	1	0.6	2	-40	-40
To	1/4"	2.5	3.5	15	120	50

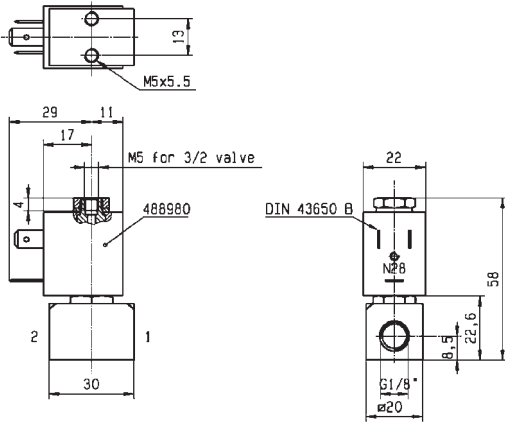

Drawing 3382

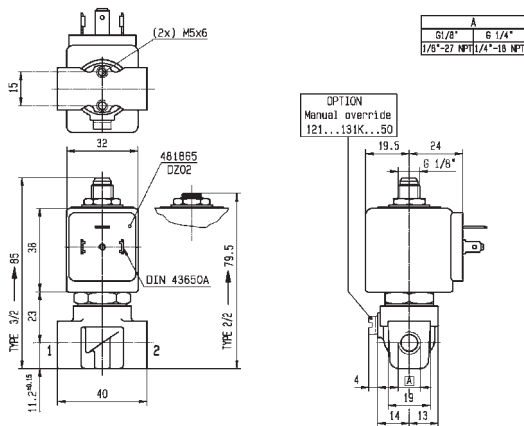

Drawing 3510

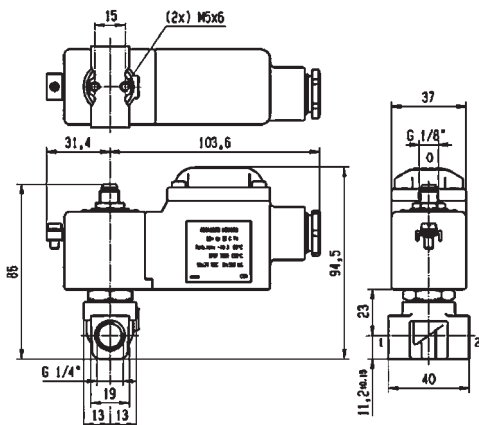

Drawing 8023

3/2

VALVES FOR DRY OR LUBRICATED AIR, NEUTRAL GASES AND LIQUIDS
DIRECT OPERATED

BRASS

PIPE MOUNTING

NORMALLY CLOSED

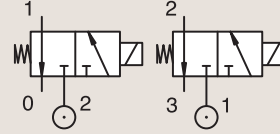

Port size	Orifice Ø		Flow factors			Operating Pressure Differential			Fluid Temp.		Seat Seal	Parker LUCIFER® Valves			IS	Power		Coil Group	Dwg. No.	
						Min	Max (MOPD)		Min	Max		Valve Ref.	Housing Ref.	Coil Ref.		AC W	DC W			
	1	(2)	1	(2)	1	(2)	bar	AC bar	DC bar	°C	°C									
BSP	1.2	1.5	0.8	1.5	0.05	0.09	0	30	-	-30	130	Ruby	E131K64	4270	481000	8	-	2.0	3510	
	1.2	1.5	0.8	1.5	0.05	0.09	0	30	30	-30	140	Ruby	E131K64	4270	486265	14	14	2.0	3510	
	1.2	1.5	0.8	1.5	0.05	0.09	0	30	-	-30	130	Ruby	E131K6450 ₁	4270	481000	8	-	2.0	3510	
	1.2	1.5	0.8	1.5	0.05	0.09	0	30	30	-30	140	Ruby	E131K6450 ₁	4270	486265	14	14	2.0	3510	
	1.5	1.5	1.5	1.5	0.09	0.09	0	-	7	-20	75	PUR	131K0497	2995	482740	-	1.6	6.0/8.0	8023	
	1.5	1.5	1.5	1.5	0.09	0.09	0	7	7	-20	75	PUR	131K0497	-	495900	2.5	2	6.0/8.0	8023	
	1.5	1.5	1.5	1.5	0.09	0.09	0	-	7	-20	75	PUR	131K0497	-	495910	*	-	0.3 to 3	6.0/8.0	8023
	1.5	1.5	1.5	1.5	0.09	0.09	0	-	7	-20	75	PUR	131K0497	2995	496125	-	1.6	6.0/8.0	8023	
	1/4"	1.5	1.5	1.5	1.5	0.09	0.09	0	16	16	-10	120	FKM	E131K04	4270	481000	8	8	2.0	3510
		1.5	1.5	1.5	1.5	0.09	0.09	0	16	16	-10	100	FKM	E131K04	2995	481865	8	9	2.0	3510
		1.5	1.5	1.5	1.5	0.09	0.09	0	16	16	-10	120	FKM	E131K04	4270	486265	14	14	2.0	3510
		1.5	1.5	1.5	1.5	0.09	0.09	0	15	15	-10	120	FKM	E131K0450 ₁	4270	481000	8	8	2.1	3510
		1.5	1.5	1.5	1.5	0.09	0.09	0	15	15	-10	100	FKM	E131K0450 ₁	2995	481865	8	9	2.1	3510
		2	3	2.5	4.5	0.15	0.27	0	10	10	-10	75	FKM	131T23	4270	481000	8	8	2.0	3223
	2	3	2.5	4.5	0.15	0.27	0	10	10	-10	75	FKM	131T23	2995	481865	8	9	2.0	3223	
	2	3	2.5	4.5	0.15	0.27	0	10	10	-10	75	FKM	131T23	4270	486265	14	14	2.0	3223	
	2	3	2.5	4.5	0.15	0.27	0	10	10	-10	75	FKM	131T2301 ₁	4270	481000	8	8	2.0	3223	
	2	3	2.5	4.5	0.15	0.27	0	10	10	-10	75	FKM	131T2301 ₁	2995	481865	8	9	2.0	3223	
2	3	2.5	4.5	0.15	0.27	0	10	10	-10	75	FKM	131T2301 ₁	4270	486265	14	14	2.0	3223		

Notes:

1. With manual override



For this page	Port size	Orifice (mm)	Kv (l/min)	MOPD (bar)	Fluid Temp (°C)	Amb Temp (°C)
From	1/4"	1.2	0.8	7	-30	-20
To	1/4"	2	2.5	30	140	50

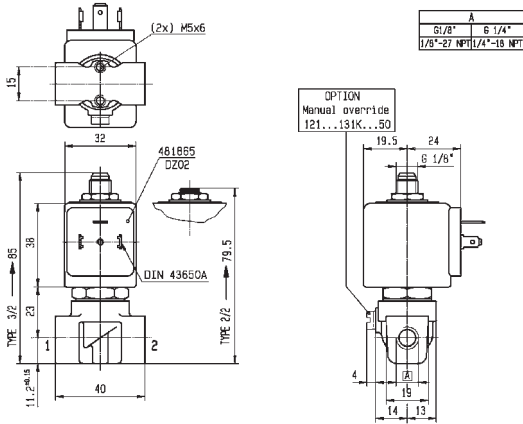

Drawing 3510

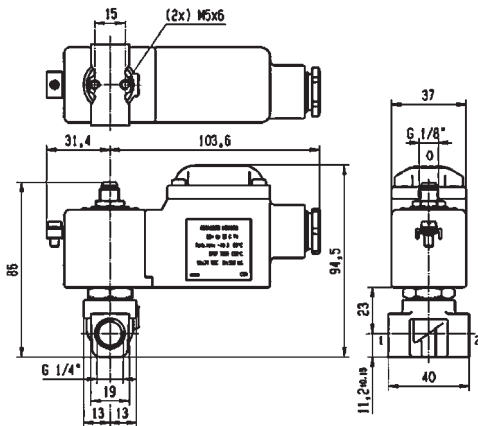

Drawing 8023

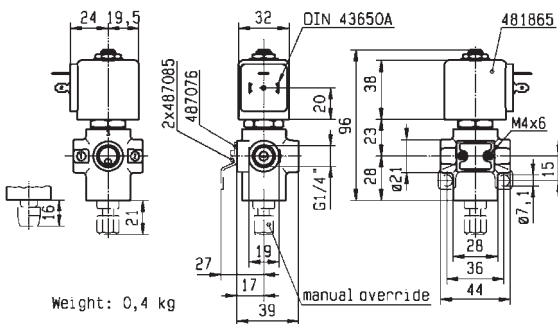

Drawing 3223

3/2

VALVES FOR DRY OR LUBRICATED AIR, NEUTRAL GASES AND LIQUIDS
DIRECT OPERATED

BRASS

PIPE MOUNTING

NORMALLY CLOSED

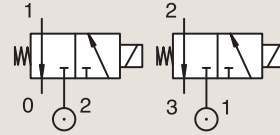

Port size	Orifice Ø		Flow factors			Operating Pressure Differential			Fluid Temp.		Seat Seal	Parker LUCIFER® Valves			Power		Coil Group	Dwg. No.	
	1	(2)	1	(2)	1	(2)	Min	Max (MOPD)	Min	Max		Valve Ref.	Housing Ref.	Coil Ref.	AC W	DC W			
	mm		Kv l/min		KV l/min		bar	AC bar	DC bar	°C									°C
1/4"	2	2.5	2.5	3.5	0.15	0.21	0	10	10	-10	120	FKM	E131K06	4270	481000	8	8	2.0	8119
	2	2.5	2.5	3.5	0.15	0.21	0	10	10	-10	100	FKM	E131K06	2995	481865	8	9	2.0	8119
	2	2.5	2.5	3.5	0.15	0.21	0	10	10	-10	120	FKM	E131K06	4270	486265	14	14	2.0	8119
	2	2.5	2.5	3.5	0.15	0.21	0	10	10	-10	120	FKM	E131K0650 ₁	4270	481000	8	8	2.1	3510
	2	2.5	2.5	3.5	0.15	0.21	0	10	10	-10	100	FKM	E131K0650 ₁	2995	481865	8	9	2.1	3510
	2.5	2.5	3	3	0.18	0.18	0	-	2	-20	75	PUR	131K0397	2995	496125	-	1.6	6.0/8.0	8023
	2.5	3.5	3.5	5.5	0.21	0.33	0	7	7	-10	75	FKM	131T29	4270	481000	8	8	2.1	3223
	2.5	3.5	3.5	5.5	0.21	0.33	0	7	7	-10	75	FKM	131T29	2995	481865	8	9	2.1	3223
	2.5	3.5	3.5	5.5	0.21	0.33	0	7	7	-10	75	FKM	131T2901 ₁	4270	481000	8	8	2.1	3223
	2.5	3.5	3.5	5.5	0.21	0.33	0	7	7	-10	75	FKM	131T2901 ₁	2995	481865	8	9	2.1	3223

Notes:

1. With manual override

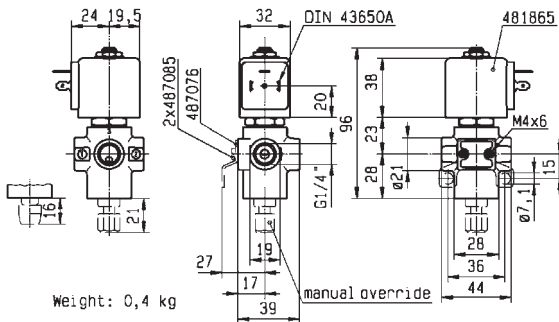

Drawing 3223



For this page	Port size	Orifice (mm)	Kv (l/min)	MOPD (bar)	Fluid Temp (°C)	Amb Temp (°C)
From	1/4"	2	2.5	2	-20	-20
To	1/4"	2.5	3.5	10	120	50

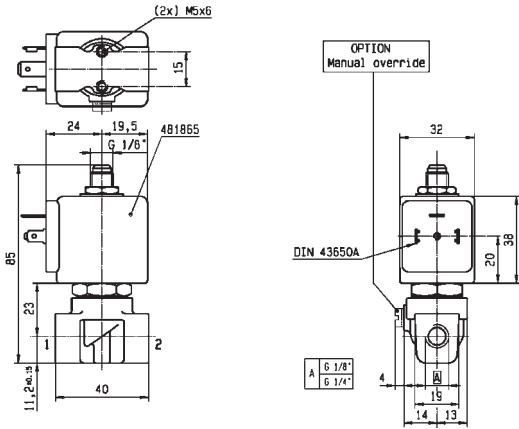

Drawing 8119

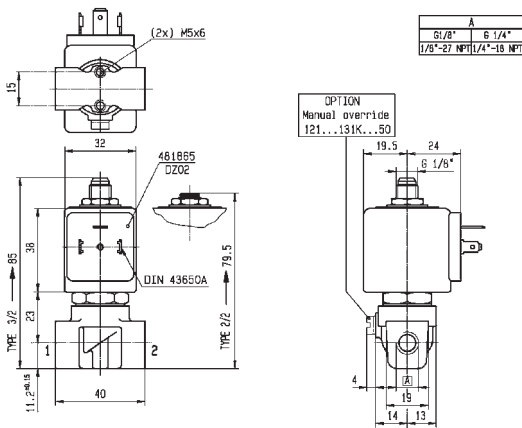

Drawing 3510

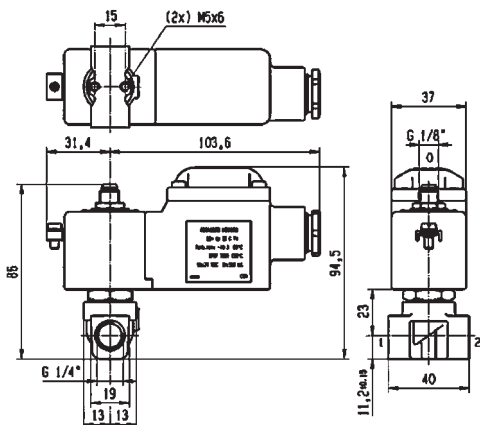

Drawing 8023

3/2

VALVES FOR DRY OR LUBRICATED AIR, NEUTRAL GASES AND LIQUIDS
DIRECT OPERATED

BRASS

PIPE MOUNTING

NORMALLY CLOSED

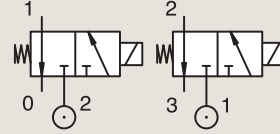

Port size	Orifice Ø		Flow factors			Operating Pressure Differential			Fluid Temp.		Seat Seal	Parker LUCIFER® Valves			Power		Coil Group	Dwg. No.	
	1	(2)	1	(2)	1	(2)	Min	Max (MOPD)	Min	Max		Valve Ref.	Housing Ref.	Coil Ref.	AC W	DC W			
BSP	mm		Kv l/min		KV l/min		bar	AC bar	DC bar	°C	°C								
1/4"	2.5	6	2.7	15	0.16	0.9	0.1	7	7	-10	75	FKM	E131E03	4270	481000	8	8	2.0	3525
	2.5	6	2.7	15	0.16	0.9	0.1	7	7	-10	75	FKM	E131E03	2995	481865	8	9	2.0	3525
	2.5	6	2.7	15	0.16	0.9	0.1	7	7	-10	75	FKM	E131E03	4270	486265	14	14	2.0	3525
	2.5	2.5	3.5	3.5	0.21	0.21	0	7	7	-10	100	FKM	E131K03	4270	481000	8	8	2.0	3510
	2.5	2.5	3.5	3.5	0.21	0.21	0	7	7	-10	100	FKM	E131K03	2995	481865	8	9	2.0	3510
	2.5	2.5	3.5	3.5	0.21	0.21	0	7	7	-40	75	PUR	E131K0308	4270	481000	8	8	2.1	3510
	2.5	2.5	3.5	3.5	0.21	0.21	0	7	7	-40	75	PUR	E131K0308	2995	481865	8	9	2.1	3510
	2.5	2.5	3.5	3.5	0.21	0.21	0	7	7	-10	120	FKM	E131K0350 ₁	4270	481000	8	8	2.1	3510
	2.5	2.5	3.5	3.5	0.21	0.21	0	7	7	-10	100	FKM	E131K0350 ₁	2995	481865	8	9	2.1	3510
	2.5	2.5	3.5	3.5	0.21	0.21	0	7	7	-30	130	Ruby	E131K63	4270	481000	8	8	2.0	3510
	2.5	2.5	3.5	3.5	0.21	0.21	0	7	7	-30	100	Ruby	E131K63	2995	481865	8	9	2.0	3510
	2.5	2.5	3.5	3.5	0.21	0.21	0	7	7	-30	130	Ruby	E131K6350 ₁	4270	481000	8	8	2.1	3510
	2.5	2.5	3.5	3.5	0.21	0.21	0	7	7	-30	100	Ruby	E131K6350 ₁	2995	481865	8	9	2.1	3510
	3	4	4.5	6	0.27	0.36	0	10	-	-10	75	FKM	131T22	4270	481044	14	-	2.2	3223
	3	4	4.5	6	0.27	0.36	0	10	-	-10	75	FKM	131T22	2995	492425	14	-	2.2	3223
	4.5	6	7	9	0.42	0.54	0	2	2	-10	75	FKM	131T21	4270	481000	8	8	2.0	3223
4.5	6	7	9	0.42	0.54	0	2	2	-10	75	FKM	131T21	2995	481865	8	9	2.0	3223	
4.5	6	7	9	0.42	0.54	0	2	2	-10	75	FKM	131T21	4270	486265	14	14	2.0	3223	

Notes:

1. With manual override



For this page	Port size	Orifice (mm)	Kv (l/min)	MOPD (bar)	Fluid Temp (°C)	Amb Temp (°C)
From	1/4"	2.5	2.7	2	-40	-40
To	1/4"	4.5	7	10	130	50

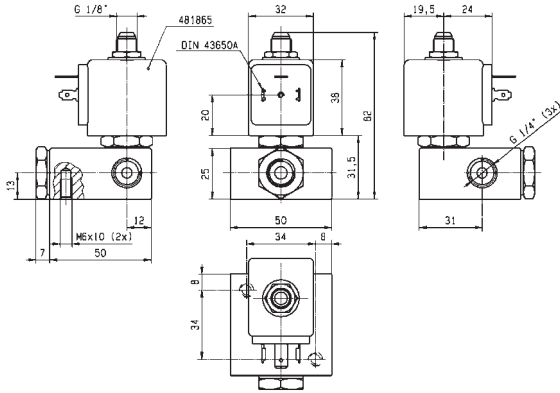

Drawing 3525

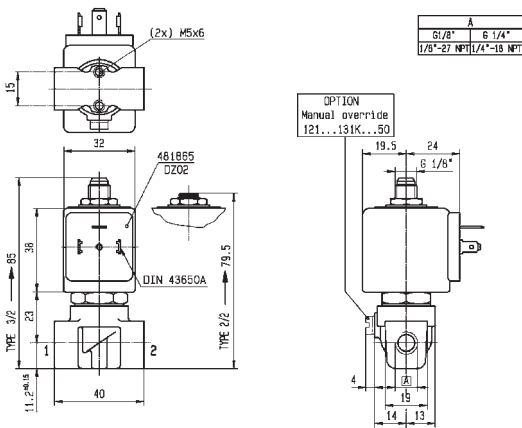

Drawing 3510

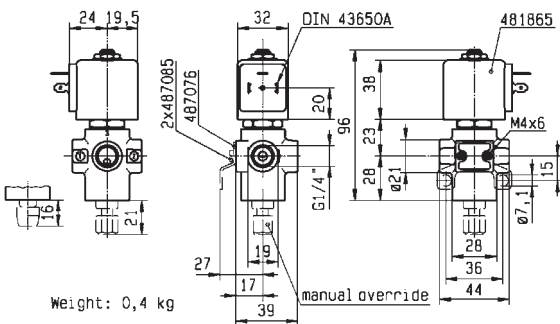

Drawing 3223

3/2

VALVES FOR DRY OR LUBRICATED AIR, NEUTRAL GASES AND LIQUIDS
DIRECT OPERATED

BRASS

PIPE MOUNTING

NORMALLY OPEN

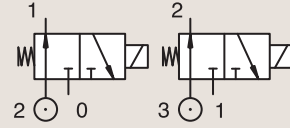

Port size	Orifice Ø		Flow factors				Operating Pressure Differential			Fluid Temp.		Seat Seal	Parker LUCIFER® Valves			Power		Coil Group	Dwg. No.
	1	(2)	1	(2)	1	(2)	Min	Max (MOPD)	Min	Max	Valve Ref.		Housing Ref.	Coil Ref.	AC W	DC W			
BSP	mm		Kv l/min		KV l/min		bar	AC bar	DC bar	°C	°C								
1/4"	1.5	1.5	1.4	1.4	0.08	0.08	0	16	16	-10	120	FKM	132K04	4270	481000	8	8	2.1	3510
	1.5	1.5	1.4	1.4	0.08	0.08	0	16	16	-10	100	FKM	132K04	2995	481865	8	9	2.1	3510
	2	2	1.8	1.8	0.10	0.10	0	10	10	-10	120	FKM	132K06	4270	481000	8	8	2.1	3510
	2	2	1.8	1.8	0.10	0.10	0	10	10	-10	100	FKM	132K06	2995	481865	8	9	2.1	3510
	2	3	2.5	4.5	0.15	0.27	0	10	5	-10	75	FKM	132T23	4270	481000	8	8	2.0	3223
	2	3	2.5	4.5	0.15	0.27	0	10	5	-10	75	FKM	132T23	2995	481865	8	9	2.0	3223
	2	3	2.5	4.5	0.15	0.27	0	-	10	-10	75	FKM	132T23	4270	486265	-	14	2.0	3223
	2	3	2.5	4.5	0.15	0.27	0	10	5	-10	75	FKM	132T2301 ₁	4270	481000	8	8	2.0	3223
	2	3	2.5	4.5	0.15	0.27	0	10	5	-10	75	FKM	132T2301 ₁	2995	481865	8	9	2.0	3223
	2	3	2.5	4.5	0.15	0.27	0	-	10	-10	75	FKM	132T2301 ₁	4270	486265	-	14	2.0	3223
	2.5	2.5	2.2	2.2	0.13	0.13	0	7	7	-10	120	FKM	132K03	4270	481000	8	8	2.1	3510
	2.5	2.5	2.2	2.2	0.13	0.13	0	7	7	-10	100	FKM	132K03	2995	481865	8	9	2.1	3510
	3	4	4.5	6	0.27	0.36	0	10	-	-10	75	FKM	132T22	4270	481044	14	-	2.2	3223
	3	4	4.5	6	0.27	0.36	0	7	-	-10	75	FKM	132T22	2995	492425	14	-	2.2	3223

Notes:

1. With manual override



For this page	Port size	Orifice (mm)	Kv (l/min)	MOPD (bar)	Fluid Temp (°C)	Amb Temp (°C)
From	1/4"	1.5	1.4	5	-10	-30
To	1/4"	3	4.5	16	120	50

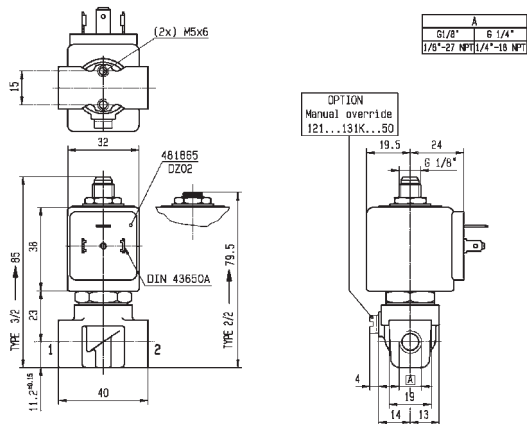

Drawing 3510

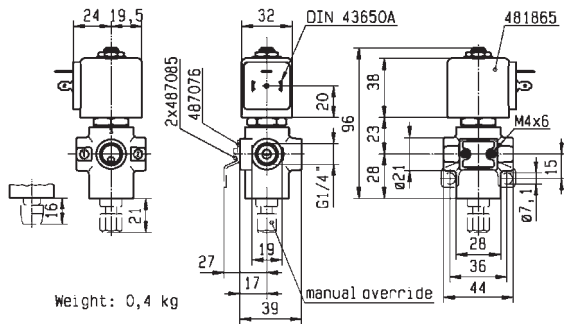

Weight: 0,4 kg



Drawing 3223

3/2

VALVES FOR DRY OR LUBRICATED AIR, NEUTRAL GASES AND LIQUIDS
DIRECT OPERATED

BRASS

PIPE MOUNTING

UNIVERSAL

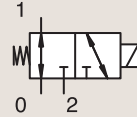

Port size	Orifice Ø		Flow factors				Operating Pressure Differential			Fluid Temp.		Seat Seal	Parker Valves			Power		Coil Group	Dwg. No.
	1	(2)	1	(2)	1	(2)	Min	Max(MOPD)	Min	Max	Valve Order Number		Valve Type	Coil Type	AC W	DC W			
BSP	mm		Kv l/min		KV l/min		bar	AC bar	DC bar	°C	°C								
1/8"	1.5	1.5	1.2	-	0.07	-	0	10	-	-10	140	FKM	362410J	PM139AV	ZB09	9	-	20.1/20.2	022
	1.5	1.5	1.2	-	0.07	-	0	-	10	-10	140	FKM	362410J	PM139AV	ZB12	-	12	20.1/20.2	022
1/4"	2	2	2	-	0.12	-	0	7	-	-10	140	FKM	362460J	PM139FV	ZB09	9	-	20.1/20.2	022
	2	2	2	-	0.12	-	0	-	7	-10	140	FKM	362460J	PM139FV	ZB12	-	12	20.1/20.2	022
	2.5	2.5	2.8	-	0.17	-	0	4	-	-10	140	FKM	362470J	PM139GV	ZB09	9	-	20.1/20.2	022
	2.5	2.5	2.8	-	0.17	-	0	-	4	-10	140	FKM	362470J	PM139GV	ZB12	-	12	20.1/20.2	022
	3.5	2.5	5	-	0.3	-	0	1	-	-10	140	FKM	362475J	PM139LV	ZB09	9	-	20.1/20.2	022
	3.5	2.5	5	-	0.3	-	0	-	1	-10	140	FKM	362475J	PM139LV	ZB12	-	12	20.1/20.2	022



For this page	Port size	Orifice (mm)	Kv (l/min)	MOPD (bar)	Fluid Temp (°C)	Amb Temp (°C)
From	1/8"	1.5	1.2	1	-10	-10
To	1/4"	3.5	5	10	140	50

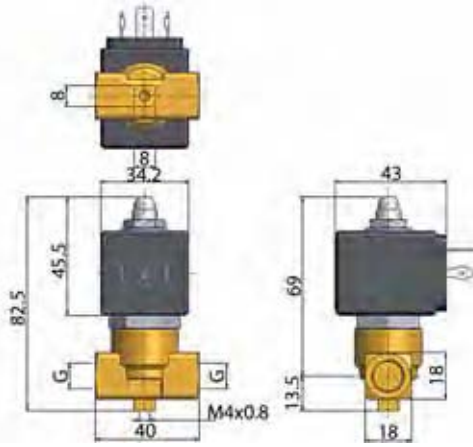

Drawing 022

3/2

VALVES FOR DRY OR LUBRICATED AIR, NEUTRAL GASES AND LIQUIDS
DIRECT OPERATED

BRASS

PIPE MOUNTING

UNIVERSAL

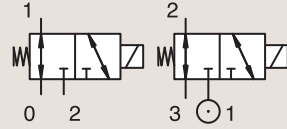

Port size	Orifice Ø		Flow factors				Operating Pressure Differential			Fluid Temp.		Seat Seal	Parker LUCIFER® Valves			IS	Power		Coil Group	Dwg. No.
	1	(2)	1	(2)	1	(2)	Min	Max (MOPD)	Min	Max	Valve Ref.		Housing Ref.	Coil Ref.	AC W		DC W			
BSP	mm		Kv l/min		KV m³/h		bar	AC bar	DC bar	°C	°C									
1/8"	1.5	1.5	1.5	1.5	0.09	0.09	0	10	10	-10	100	FKM	E133K14	2995	481865		8	9	2.1	3510
	1.5	1.5	1.5	1.5	0.09	0.09	0	10	10	-10	120	FKM	E133K14	4270	481000		8	8	2.1	3510
	2	2	2.5	2.5	0.15	0.15	0	7	7	-10	100	FKM	E133K16	2995	481865		8	9	2.1	3510
	2	2	2.5	2.5	0.15	0.15	0	7	7	-10	120	FKM	E133K16	4270	481000		8	8	2.1	3510
	2.5	2.5	3.5	3.5	0.21	0.21	0	4	4	-10	100	FKM	E133K13	2995	481865		8	9	2.1	3510
	2.5	2.5	3.5	3.5	0.21	0.21	0	4	4	-10	120	FKM	E133K13	4270	481000		8	8	2.1	3510
1/4"	0.8	0.8	0.3	0.3	0.02	0.02	0	30	30	-10	100	FKM	E133K05	2995	481865		8	9	2.1	3510
	0.8	0.8	0.3	0.3	0.02	0.02	0	30	30	-10	120	FKM	E133K05	4270	481000		8	8	2.1	3510
	0.8	0.8	0.3	0.3	0.02	0.02	0	30	30	-10	120	FKM	E133K05	4270	486265		14	14	2.0	3510
	1.5	1.5	1.5	1.5	0.09	0.09	0	-	3	-20	75	PUR	133K0497	2995	482740		-	1.6	6.0/8.0	8023
	1.5	1.5	1.5	1.5	0.09	0.09	0	3	3	-20	75	PUR	133K0497	-	495900		2.5	2	6.0/8.0	8023
	1.5	1.5	1.5	1.5	0.09	0.09	0	-	3	-20	75	PUR	133K0497	-	495910	*	-	0.3 to 3	6.0/8.0	8023
	1.5	1.5	1.5	1.5	0.09	0.09	0	-	3	-20	75	PUR	133K0497	2995	496125		-	1.6	6.0/8.0	8023
	1.5	1.5	1.5	1.5	0.09	0.09	0	10	10	-10	100	FKM	E133K04	2995	481865		8	9	2.0	3510
	1.5	1.5	1.5	1.5	0.09	0.09	0	10	10	-10	120	FKM	E133K04	4270	481000		8	8	2.0	3510
	1.5	1.5	1.5	1.5	0.09	0.09	0	10	10	-10	120	FKM	E133K04	4270	486265		14	14	2.0	3510
	1.5	1.5	1.5	1.5	0.09	0.09	0	10	10	-10	100	FKM	E133K0450 ₁	2995	481865		8	9	2.1	3510
	1.5	1.5	1.5	1.5	0.09	0.09	0	10	10	-10	120	FKM	E133K0450 ₁	4270	481000		8	8	2.1	3510
	2	2	2.5	2.5	0.15	0.15	0	7	7	-10	75	FKM	133T23	2995	481865		8	9	2.1	3223
	2	2	2.5	2.5	0.15	0.15	0	7	7	-10	75	FKM	133T23	4270	481000		8	8	2.1	3223
	2	2	2.5	2.5	0.15	0.15	0	7	7	-10	75	FKM	133T2301 ₁	2995	481865		8	9	2.1	3223
	2	2	2.5	2.5	0.15	0.15	0	7	7	-10	75	FKM	133T2301 ₁	4270	481000		8	8	2.1	3223
	2	2	2.5	2.5	0.15	0.15	0	7	7	-10	100	FKM	E133K06	2995	481865		8	9	2.0/3.0	3510
	2	2	2.5	2.5	0.15	0.15	0	7	7	-10	120	FKM	E133K06	4270	481000		8	8	2.0/3.0	3510
	2	2	2.5	2.5	0.15	0.15	0	7	7	-10	120	FKM	E133K06	4270	486265		14	14	2.0/3.0	3510
	2	2	2.5	2.5	0.15	0.15	0	7	7	-10	100	FKM	E133K0650 ₁	2995	481865		8	9	2.1	3510
	2	2	2.5	2.5	0.15	0.15	0	7	7	-10	120	FKM	E133K0650 ₁	4270	481000		8	8	2.1	3510
	2.5	2.5	3.5	3.5	0.21	0.21	0	4	4	-10	100	FKM	E133K03	2995	481865		8	9	2.0	3510
	2.5	2.5	3.5	3.5	0.21	0.21	0	4	4	-10	120	FKM	E133K03	4270	481000		8	8	2.0	3510
	2.5	2.5	3.5	3.5	0.21	0.21	0	4	4	-10	120	FKM	E133K03	4270	486265		14	14	2.0	3510
	2.5	2.5	3.5	3.5	0.21	0.21	0	4	4	-10	100	FKM	E133K0350 ₁	2995	481865		8	9	2.1	3510
	2.5	2.5	3.5	3.5	0.21	0.21	0	4	4	-10	120	FKM	E133K0350 ₁	4270	481000		8	8	2.1	3510
	3	3	4.5	4.5	0.27	0.27	0	2	2	-10	75	FKM	133T21	2995	481865		8	9	2.1	3223
	3	3	4.5	4.5	0.27	0.27	0	2	2	-10	75	FKM	133T21	4270	481000		8	8	2.1	3223

Notes:

1. With manual override



3 WAY VALVES



For this page	Port size	Orifice (mm)	Kv (l/min)	MOPD (bar)	Fluid Temp (°C)	Amb Temp (°C)
From	1/8"	0.8	0.3	2	-20	-20
To	1/4"	3	4.5	30	120	50

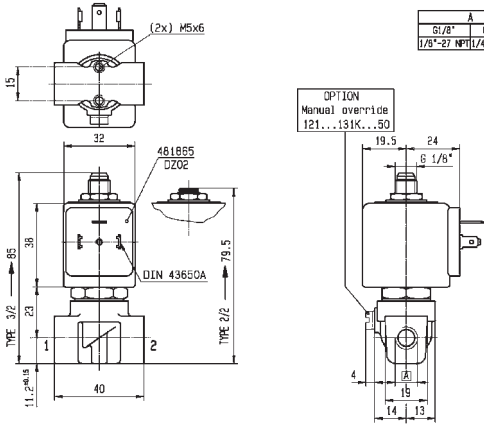

Drawing 3510

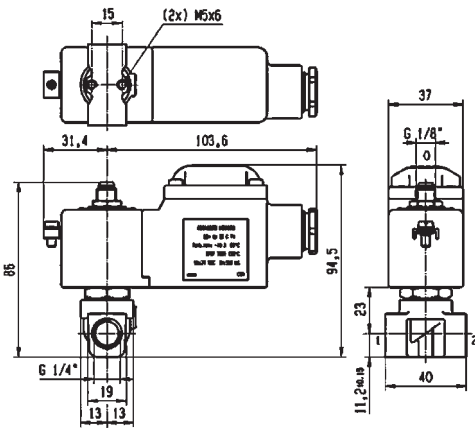

Drawing 8023

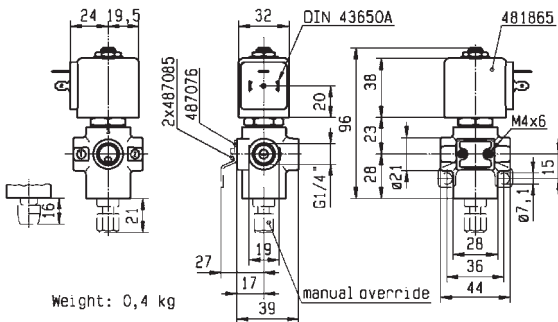

Drawing 3223

3/2

VALVES FOR DRY OR LUBRICATED AIR, NEUTRAL GASES AND LIQUIDS
DIRECT OPERATED

BRASS

PIPE MOUNTING

UNIVERSAL

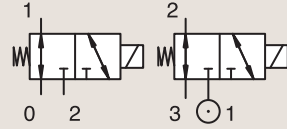

Port size	Orifice Ø		Flow factors			Operating Pressure Differential			Fluid Temp.		Seat Seal	Parker LUCIFER® Valves			Power		Coil Group	Dwg. No.	
	1	(2)	1	(2)	1	(2)	Min	Max (MOPD)	Min	Max		Valve Ref.	Housing Ref.	Coil Ref.	AC W	DC W			
BSP	mm		Kv	I/min	KV	m³/h	bar	AC bar	DC bar	°C	°C								
1/4"	3	3	4.5	4.5	0.27	0.27	0	2	2	-10	75	FKM	133T2101 ₁	2995	481865	8	9	2.1	3223
	3	3	4.5	4.5	0.27	0.27	0	2	2	-10	75	FKM	133T2101 ₁	4270	481000	8	8	2.1	3223

Notes:

1. With manual override

BRASS

PIPE MOUNTING

CONTROL BY ELECTRIC IMPULSE

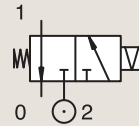

Port size	Orifice Ø		Flow factors			Operating Pressure Differential			Fluid Temp.		Seat Seal	Parker LUCIFER® Valves			Power		Coil Group	Dwg. No.	
	1	(2)	1	(2)	1	(2)	Min	Max (MOPD)	Min	Max		Valve Ref.	Housing Ref.	Coil Ref.	AC W	DC W			
BSP	mm		Kv	I/min	KV	I/min	bar	AC bar	DC bar	°C	°C								
1/4"	1.5	1.5	1.5	1.5	0.09	0.09	0	-	16	-10	100	FKM	135K04	4269	485400	-	13	4.0	8104



For this page	Port size	Orifice (mm)	Kv (l/min)	MOPD (bar)	Fluid Temp (°C)	Amb Temp (°C)
From	1/4"	1.5	1.5	2	-10	-10
To	1/4"	3	4.5	16	100	50

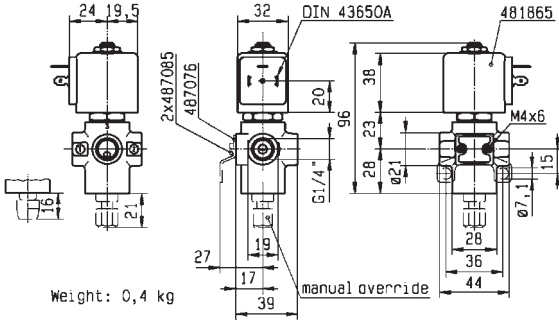

Drawing 3223

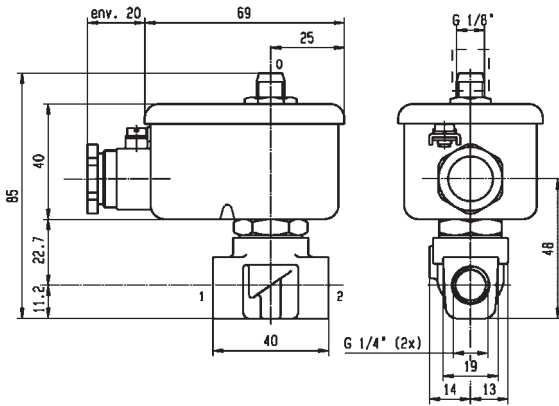

Drawing 8104

3/2

VALVES FOR DRY OR LUBRICATED AIR, NEUTRAL GASES AND LIQUIDS
DIRECT OPERATED

BRASS

SUB-BASE MOUNTING

NORMALLY CLOSED

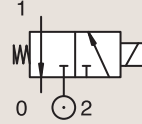

Port size	Orifice Ø		Flow factors				Operating Pressure Differential			Fluid Temp.		Seat Seal	Parker Valves			Power		Coil Group	Dwg. No.
	1	(2)	1	(2)	1	(2)	Min	Max(MOPD)		Min	Max		Valve Order Number	Valve Type	Coil Type	AC W	DC W		
								bar	AC bar										
SB	1.3	2.5	1	-	0.06	-	0	20	10	-30	140	Ruby	360490J ₁	PM128GR	ZB09	9	-	20.1/20.2	009
	1.3	2.5	1	-	0.06	-	0	20	10	-30	140	Ruby	360480J ₁	PM128IR	YB09	9	-	20.1/20.2	010
	1.3	2.5	1	-	0.06	-	0	20	10	-30	140	Ruby	360480J ₁	PM128IR	ZB09	9	-	20.1/20.2	010
	1.3	2.5	1	-	0.06	-	0	20	10	-10	140	FKM	360506 ₁	PM128ISV	ZB09	9	-	20.1/20.2	010
	1.3	2.5	1	-	0.06	-	0	20	10	-10	140	FKM	360479J ₁	PM128IV	ZB09	9	-	20.1/20.2	010

Notes:

1. Maximum static pressure: 14.5 Bar (for Viton sealing, maximum static pressure: 12 Bar)



For this page	Port size	Orifice (mm)	Kv (l/min)	MOPD (bar)	Fluid Temp (°C)	Amb Temp (°C)
From	SB	1.3	1	10	-30	-10
To	SB	1.3	1	20	140	50



Drawing 009

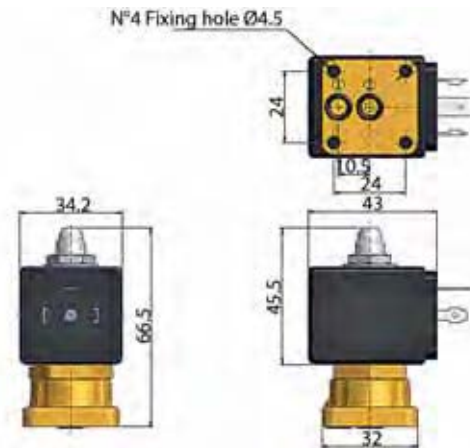

Drawing 010

3/2

VALVES FOR DRY OR LUBRICATED AIR, NEUTRAL GASES AND LIQUIDS
DIRECT OPERATED

BRASS
SUB-BASE MOUNTING

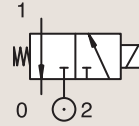

NORMALLY CLOSED

Port size	Orifice Ø		Flow factors			Operating Pressure Differential			Fluid Temp.		Seat Seal	Parker LUCIFER® Valves			IS	Power		Coil Group	Dwg. No.	
	1	(2)	1	(2)	1	(2)	Min	Max (MOPD)	Min	Max		Valve Ref.	Housing Ref.	Coil Ref.		AC W	DC W			
	mm		Kv l/min		KV l/min		bar	AC bar	DC bar	°C										°C
SB	1.2	1.5	0.7	0.9	0.04	0.05	0	10	10	-10	75	FKM	131M75	8993	488980		2	2.5	1.1	3383
	1.2	1.5	0.7	0.9	0.04	0.05	0	10	10	-10	75	FKM	131M7550	8993	488980		2	2.5	1.1	3383
	1.5	1.5	0.9	0.9	0.05	0.05	0	7	7	-10	75	FKM	131M74	8993	488980		2	2.5	1.1	3383
	1.5	1.5	0.9	0.9	0.05	0.05	0	7	7	-10	75	FKM	131M7450	8993	488980		2	2.5	1.1	3383
	1	1	0.6	0.6	0.03	0.03	0	-	10	-10	75	FKM	131F4490	2995	483580.01	*	-	0.5 to 3	7.0/8.0	7057
	1	1	0.6	0.6	0.03	0.03	0	-	10	-10	75	FKM	131F4490	-	488660.01	*	-	0.3 to 3	7.0/8.0	7057
	1	1	0.6	0.6	0.03	0.03	0	-	10	-10	75	FKM	131F4490	-	495910	*	-	0.3 to 3	7.0/8.0	7057
	1.5	2	1.5	2.2	0.09	0.13	0	-	16	-10	100	FKM	131F4410	2995	481865		-	9	2.1	3509
	1.5	1.5	1.5	1.5	0.09	0.09	0	-	7	-20	75	PUR	131F4497	2995	482740		-	1.6	6.0/8.0	8022
	1.5	1.5	1.5	1.5	0.09	0.09	0	7	7	-20	75	PUR	131F4497	-	495900		2.5	2	6.0/8.0	8022
	1.5	1.5	1.5	1.5	0.09	0.09	0	-	7	-20	75	PUR	131F4497	-	495910	*	-	0.3 to 3	6.0/8.0	8022
	1.5	1.5	1.5	1.5	0.09	0.09	0	-	7	-20	75	PUR	131F4497	2995	496125		-	1.6	6.0/8.0	8022

Notes:

1. With manual override

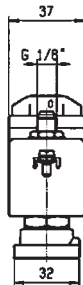
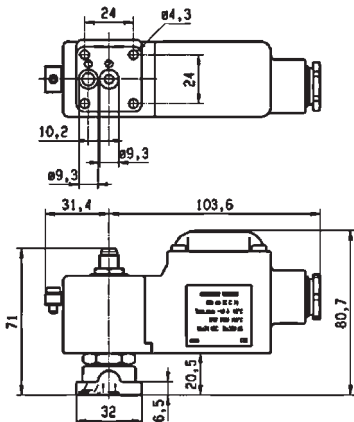

Drawing 8022



For this page	Port size	Orifice (mm)	Kv (l/min)	MOPD (bar)	Fluid Temp (°C)	Amb Temp (°C)
From	SB	1	0.6	7	-20	-20
To	SB	1.5	1.5	16	100	50

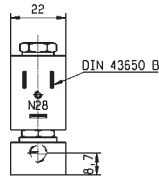
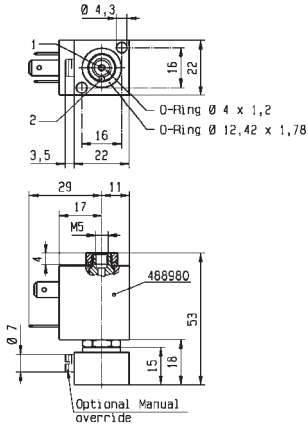

Drawing 3383

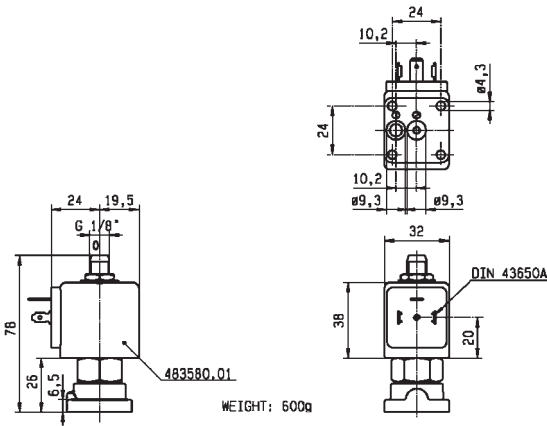

Drawing 7057

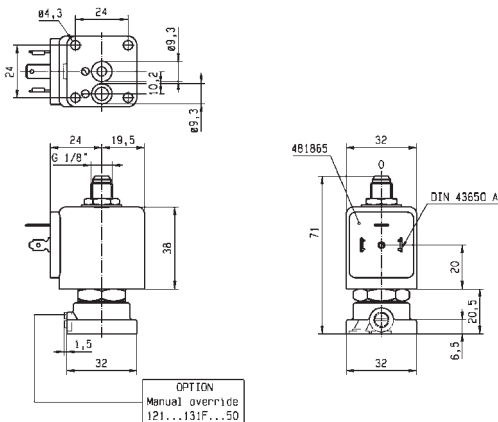

Drawing 3509

3/2

VALVES FOR DRY OR LUBRICATED AIR, NEUTRAL GASES AND LIQUIDS
DIRECT OPERATED

BRASS

SUB-BASE MOUNTING

NORMALLY CLOSED

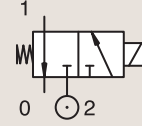

Port size	Orifice Ø		Flow factors			Operating Pressure Differential			Fluid Temp.		Seat Seal	Parker LUCIFER® Valves			Power		Coil Group	Dwg. No.	
	1	(2)	1	(2)	1	(2)	Min	Max (MOPD)		Min		Max	Valve Ref.	Housing Ref.	Coil Ref.	AC W			DC W
	mm		Kv l/min		KV m³/h		bar	AC bar	DC bar	°C		°C							
SB	1.5	1.5	1.5	1.5	0.09	0.09	0	15	15	-10	100	FKM	E131F44	2995	481865	8	9	2.1	3509
	1.5	1.5	1.5	1.5	0.09	0.09	0	15	15	-10	120	FKM	E131F44	4270	481000	8	8	2.1	3509
	1.5	1.5	1.5	1.5	0.09	0.09	0	15	15	-10	100	FKM	E131F4450 ₁	2995	481865	8	9	2.1	3509
	1.5	1.5	1.5	1.5	0.09	0.09	0	15	15	-10	100	FKM	E131F4450 ₁	4270	481000	8	8	2.1	3509
	2	2.5	2.5	3.5	0.15	0.21	0	10	10	-10	100	FKM	131F46	2995	481865	8	9	2.1	3509
	2	2.5	2.5	3.5	0.15	0.21	0	10	10	-10	120	FKM	131F46	4270	481000	8	8	2.1	3509
	2	2.5	2.5	3.5	0.15	0.21	0	10	10	-10	100	FKM	131F4650 ₁	2995	481865	8	9	2.1	3509
	2	2.5	2.5	3.5	0.15	0.21	0	10	10	-10	120	FKM	131F4650 ₁	4270	481000	8	8	2.1	3509
	2.5	2.5	3.5	3.5	0.21	0.21	0	7	7	-10	100	FKM	E131F43	2995	481865	8	9	2.1	3509
	2.5	2.5	3.5	3.5	0.21	0.21	0	7	7	-10	120	FKM	E131F43	4270	481000	8	8	2.1	3509
	2.5	2.5	3.5	3.5	0.21	0.21	0	7	7	-10	100	FKM	E131F4350 ₁	2995	481865	8	9	2.0	3509
	2.5	2.5	3.5	3.5	0.21	0.21	0	7	7	-10	120	FKM	E131F4350 ₁	4270	481000	8	8	2.0	3509
2.5	2.5	3.5	3.5	0.21	0.21	0	7	7	-10	100	FKM	E131F4350 ₁	4270	486265	14	14	2.0	3509	

Notes:

1. With manual override

BRASS

SUB-BASE MOUNTING

NORMALLY OPEN

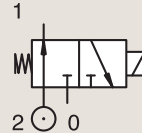

Port size	Orifice Ø		Flow factors			Operating Pressure Differential			Fluid Temp.		Seat Seal	Parker LUCIFER® Valves			Power		Coil Group	Dwg. No.	
	1	(2)	1	(2)	1	(2)	Min	Max (MOPD)		Min		Max	Valve Ref.	Housing Ref.	Coil Ref.	AC W			DC W
	mm		Kv l/min		KV m³/h		bar	AC bar	DC bar	°C		°C							
SB	1.5	1.5	1.4	1.4	0.084	0.084	0	15	15	-10	75	FKM	132F44	4270	481000	8	8	2.1	3509
	1.5	1.5	1.4	1.4	0.084	0.084	0	15	15	-10	75	FKM	132F44	2995	481865	8	9	2.1	3509
	2	2	1.8	1.8	0.108	0.108	0	10	10	-10	120	FKM	132F46	4270	481000	8	8	2.1	3509
	2	2	1.8	1.8	0.108	0.108	0	10	10	-10	100	FKM	132F46	2995	481865	8	9	2.1	3509
	2.5	2.5	2.2	2.2	0.132	0.132	0	7	7	-10	75	FKM	132F43	4270	481000	8	8	2.0	3509
	2.5	2.5	2.2	2.2	0.132	0.132	0	7	7	-10	75	FKM	132F43	2995	481865	8	9	2.0	3509
	2.5	2.5	2.2	2.2	0.132	0.132	0	7	7	-10	75	FKM	132F43	4270	486265	14	14	2.0	3509



For this page	Port size	Orifice (mm)	Kv (l/min)	MOPD (bar)	Fluid Temp (°C)	Amb Temp (°C)
From	SB	1.5	1.4	7	-10	-30
To	SB	2.5	3.5	15	120	50

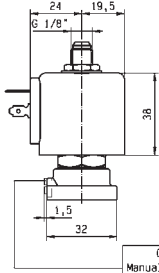
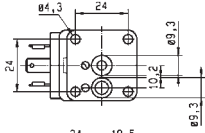

OPTION
Manual override
121...131F...50

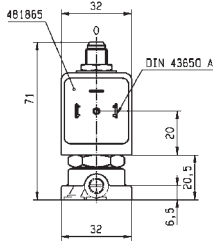

Drawing 3509

3/2

VALVES FOR DRY OR LUBRICATED AIR, NEUTRAL GASES AND LIQUIDS
DIRECT OPERATED

BRASS
SUB-BASE MOUNTING

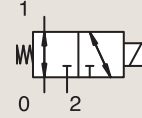

UNIVERSAL

Port size	Orifice Ø		Flow factors				Operating Pressure Differential			Fluid Temp.		Seat Seal	Parker LUCIFER® Valves			Power		Coil Group	Dwg. No.
	1	(2)	1	(2)	1	(2)	Min	Max (MOPD)		Min	Max		Valve Ref.	Housing Ref.	Coil Ref.	AC W	DC W		
	mm		Kv l/min		KV l/min		bar	AC bar	DC bar	°C	°C								
SB	1.5	1.5	1.5	1.5	0.09	0.09	0	10	10	-10	100	FKM	E133F4450 ₁	4270	481000	8	8	2.1	3509
	1.5	1.5	1.5	1.5	0.09	0.09	0	10	10	-10	120	FKM	E133F4450 ₁	2995	481865	8	9	2.1	3509
	1.5	1.5	1.5	1.5	0.09	0.09	0	10	10	-10	120	FKM	E133F44	4270	481000	8	8	2.1	3509
	1.5	1.5	1.5	1.5	0.09	0.09	0	10	10	-10	100	FKM	E133F44	2995	481865	8	9	2.1	3509
	2	2	2.5	2.5	0.15	0.15	0	7	7	-10	120	FKM	133F46	4270	481000	8	8	2.1	3509
	2	2	2.5	2.5	0.15	0.15	0	7	7	-10	100	FKM	133F46	2995	481865	8	9	2.1	3509
	2.5	2.5	3.5	3.5	0.21	0.21	0	4	4	-10	120	FKM	E133F43	4270	481000	8	8	2.1	3509
	2.5	2.5	3.5	3.5	0.21	0.21	0	4	4	-10	100	FKM	E133F43	2995	481865	8	9	2.1	3509

Notes:

1. With manual override



For this page	Port size	Orifice (mm)	Kv (l/min)	MOPD (bar)	Fluid Temp (°C)	Amb Temp (°C)
From	SB	1.5	1.5	4	-10	-10
To	SB	2.5	3.5	10	120	50

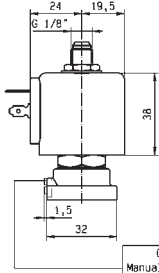
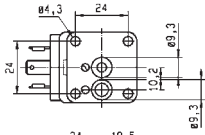

OPTION
Manual override
121...131F...50

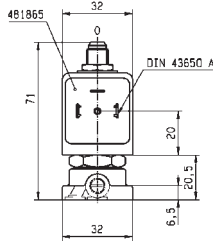

Drawing 3509

3/2

VALVES FOR DRY OR LUBRICATED AIR, NEUTRAL GASES AND LIQUIDS
DIRECT OPERATED

ANODIZED ALUMINIUM

BANJO

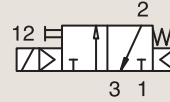

NORMALLY CLOSED

Port size	Orifice Ø 1	Flow factor Qn l/min	Operating Pressure Differential		Fluid Temp.		Seat Seal	Valve Ref.	Parker LUCIFER® Valves			Power		Coil Group	Dwg. No.
			Min	Max (MOPD)	Min	Max			Housing Ref.	Coil Ref.	AC W	DC W			
1/8"	1.2	50	0	10	10	-10	50	NBR	131B14 ₁₂	-	496131	3	3	1.2	8227
	1.2	50	0	10	10	-10	50	NBR	131B14 ₁₂	-	496482	3	3	1.2	8227
	1.2	50	0	10	10	-10	50	NBR	131B14 ₁₂	-	496637	3	3	1.2	8227

Notes:

1. Valve only compatible with air and neutral gases
2. With manual override

ANODIZED ALUMINIUM

BANJO

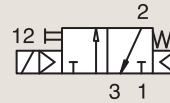

NORMALLY CLOSED

Port size	Orifice Ø 1	Flow factor Qn l/min	Operating Pressure Differential		Fluid Temp.		Seat Seal	Valve Ref.	Parker LUCIFER® Valves			Power		Coil Group	Dwg. No.
			Min	Max (MOPD)	Min	Max			Housing Ref.	Coil Ref.	AC W	DC W			
1/4"	1.2	50	0	10	10	-10	50	NBR	131B04 ₁₂	-	496131	3	3	1.2	8226
	1.2	50	0	10	10	-10	50	NBR	131B04 ₁₂	-	496482	3	3	1.2	8226
	1.2	50	0	10	10	-10	50	NBR	131B04 ₁₂	-	496637	3	3	1.2	8226

Notes:

1. Valve only compatible with air and neutral gases
2. With manual override



For this page	Port size	Orifice (mm)	Qn (l/min)	MOPD (bar)	Fluid Temp (°C)	Amb Temp (°C)
From	1/8"	1.2	50	10	-10	-10
To	1/8"	1.2	50	10	50	50

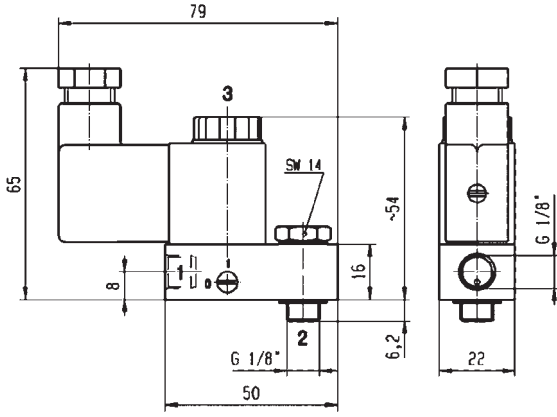

Drawing 8227

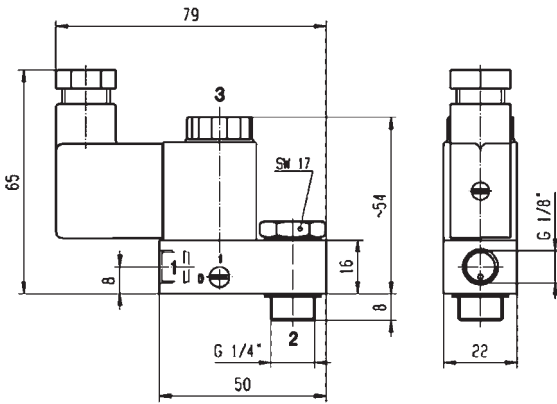

Drawing 8226

3 WAY VALVES

3/2

VALVES FOR DRY OR LUBRICATED AIR, NEUTRAL GASES AND LIQUIDS
DIRECT OPERATED

303 STAINLESS ST.
SUB-BASE MOUNTING

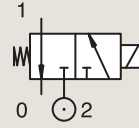

NORMALLY CLOSED

Port size	Orifice Ø		Flow factors				Operating Pressure Differential			Fluid Temp.		Seat Seal	Parker LUCIFER® Valves			Power		Coil Group	Dwg. No.
	1	(2)	1	(2)	1	(2)	Min	Max (MOPD)		Min	Max		Valve Ref.	Housing Ref.	Coil Ref.	AC W	DC W		
	mm		Kv l/min		KV l/min		bar	AC bar	DC bar	°C	°C								
SB	1.5	1.5	1.5	2.2	0.09	0.13	0	15	15	-10	100	NBR	131F5406	2995	481865	8	9	2.1	3509

3 WAY VALVES

For this page	Port size	Orifice (mm)	Kv (l/min)	MOPD (bar)	Fluid Temp (°C)	Amb Temp (°C)
From	SB	1.5	1.5	15	-10	-10
To	SB	1.5	1.5	15	100	50

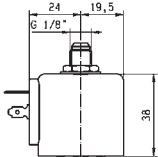
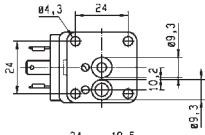

OPTION
Manual override
121...13!F...50

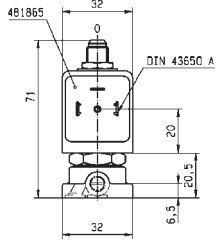

Drawing 3509

3/2

VALVES FOR DRY OR LUBRICATED AIR, NEUTRAL GASES AND LIQUIDS
DIRECT OPERATED

POM

SUB-BASE MOUNTING

NORMALLY CLOSED

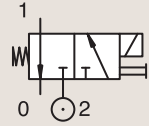

Port size	Orifice Ø		Flow factors				Operating Pressure Differential			Fluid Temp.		Seat Seal	Parker LUCIFER® Valves			Power		Coil Group	Dwg. No.
	1	(2)	1	(2)	1	(2)	Min	Max (MOPD)		Min	Max		Valve Ref.	Housing Ref.	Coil Ref.	AC W	DC W		
	mm		Kv l/min		KV l/min		bar	AC bar	DC bar	°C	°C								
SB	2	2	2	2	0.12	0.12	0	10	10	-10	50	FKM	E131F26 ₁₂	2995	481865	8	9	2.1/3.0	3601
	2	2	2	2	0.12	0.12	0	10	10	-10	50	FKM	E131F26 ₂	2995	482730	6	7	2.1/3.0	3601

Notes:

- 1. 20% Switch-on - max. 2 min
- 2. With manual override



For this page	Port size	Orifice (mm)	Kv (l/min)	MOPD (bar)	Fluid Temp (°C)	Amb Temp (°C)
From	SB	2	2	10	-10	-10
To	SB	2	2	10	50	50

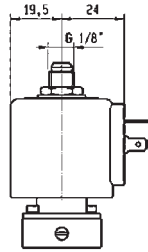
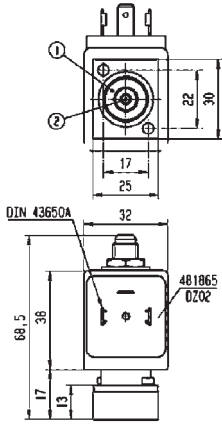

Drawing 3601

3/2

VALVES FOR DRY OR LUBRICATED AIR, NEUTRAL GASES AND LIQUIDS
PILOT OPERATED



Industrial Equipment



Process

ANODIZED ALUMINIUM PIPE MOUNTING

NORMALLY CLOSED

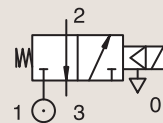

Port size	Orifice Ø		Flow factors				Operating Pressure Differential			Fluid Temp.		Seat Seal	Parker LUCIFER® Valves			IS	Power		Coil Group	Dwg. No.
	1	(2)	1	(2)	1	(2)	Min	Max (MOPD)		Min	Max		Valve Ref.	Housing Ref.	Coil Ref.		AC W	DC W		
								AC bar	DC bar											
BSP	6.5	6.5	10	-	0.6	-	1	-	10	-10	55	NBR	331B7490 ₁	2995	483580.01	*	-	0.5 to 3	7.0/8.0	8270
	6.5	6.5	10	-	0.6	-	1	-	10	-10	75	NBR	331B7490 ₁	-	488660.01	*	-	0.3 to 3	7.0/8.0	8270
	6.5	6.5	10	-	0.6	-	1	-	10	-10	75	NBR	331B7490 ₁	-	495910	*	-	0.3 to 3	7.0/8.0	8270
1/4"	6.5	-	10	-	0.6	-	1	10	10	-10	75	NBR	E331B74 ₁₃	2995	481865		8	9	2.1	3240
	6.5	-	10	-	0.6	-	1	10	10	-10	75	NBR	E331B74 ₁₃	4270	485100		8	8	2.1	3240
	8	8	20	20	1.2	1.2	1	15	15	-10	75	FKM	E331B01 ₂	4270	481000		8	8	2.1	3234
	8	8	20	20	1.2	1.2	1	15	15	-10	75	FKM	E331B01 ₂	2995	481865		8	9	2.1	3234
	8	8	20	20	1.2	1.2	1	15	15	-10	75	FKM	E331B01 ₂	-	483371		8	8	2.1	3234

Notes:

1. Valve only compatible with air and neutral gases
2. Valve only compatible with hydraulic oil and air/neutral gases
3. With manual override



For this page	Port size	Orifice (mm)	Kv (l/min)	MOPD (bar)	Fluid Temp (°C)	Amb Temp (°C)
From	1/4"	6.5	10	10	-10	-10
To	1/4"	8	20	15	75	50

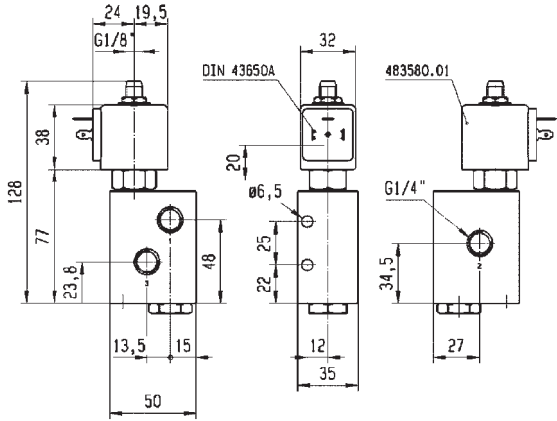

Drawing 8270

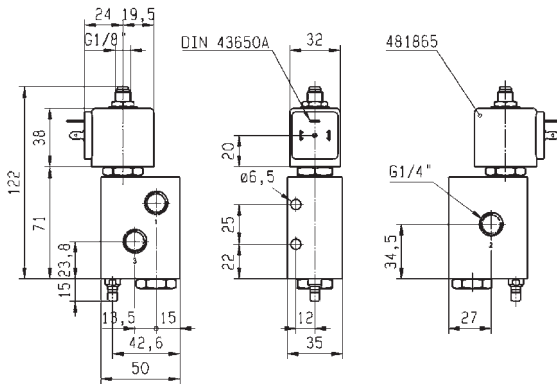

Weight: 0,51 kg



Drawing 3240

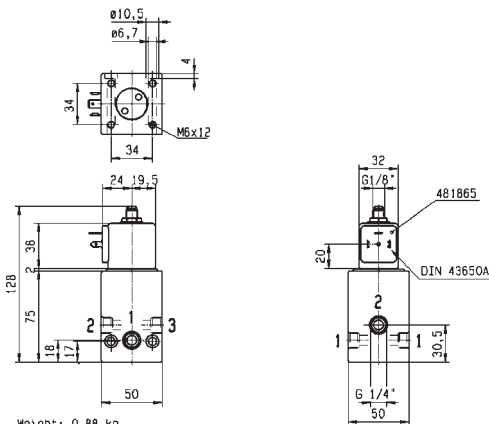

Weight: 0,88 kg



Drawing 3234

3/2

VALVES FOR DRY OR LUBRICATED AIR, NEUTRAL GASES AND LIQUIDS
PILOT OPERATED

ANODIZED ALUMINIUM
PIPE MOUNTING

NORMALLY CLOSED

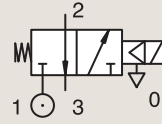

Port size	Orifice Ø		Flow factors		Operating Pressure Differential			Fluid Temp.		Seat Seal	Parker LUCIFER® Valves			Power		Coil Group	Dwg. No.		
	1	(2)	1	(2)	1	(2)	Min	Max (MOPD)	Min		Max	Valve Ref.	Housing Ref.	Coil Ref.	AC W			DC W	
BSP	mm		Kv l/min		KV l/min		bar	AC bar	DC bar	°C	°C								
1/2"	14	14	-	-	-	-	1	15	-	-10	75	FKM	E331B21 ₁	2995	482722	10	-	2.1	3238
	14	14	-	-	-	-	1	15	15	-10	75	FKM	E331B21 ₁	-	483371	8	8	2.1	3238

Notes:

1. Valve only compatible with air and neutral gases

ANODIZED ALUMINIUM
PIPE MOUNTING

NORMALLY OPEN

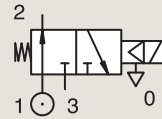

Port size	Orifice Ø		Flow factors		Operating Pressure Differential			Fluid Temp.		Seat Seal	Parker LUCIFER® Valves			Power		Coil Group	Dwg. No.		
	1	(2)	1	(2)	1	(2)	Min	Max (MOPD)	Min		Max	Valve Ref.	Housing Ref.	Coil Ref.	AC W			DC W	
BSP	mm		Kv l/min		KV l/min		bar	AC bar	DC bar	°C	°C								
1/4"	8	8	10	10	0.6	0.6	1	40	40	-10	75	PCTFE	332B02 ₁₂	2995	481865	8	9	2.1	8114
	8	8	10	10	0.6	0.6	1	40	40	-10	75	PCTFE	332B02 ₁₂	4270	481000	8	8	2.1	8114
	8	8	20	20	1.2	1.2	1	15	15	-10	75	FKM	E332B01 ₂	2995	481865	8	9	2.1	3234
	8	8	20	20	1.2	1.2	1	15	15	-10	75	FKM	E332B01 ₂	4270	481000	8	8	2.1	3234
	8	8	20	20	1.2	1.2	1	15	15	-10	75	FKM	E332B01 ₂	-	483371	8	8	2.1	3234

Notes:

1. Pilot seat discs in Kel-F (PCTFE); valve with pilot return pipe
2. Valve only compatible with hydraulic oil and air/neutral gases



For this page	Port size	Orifice (mm)	Kv (l/min)	MOPD (bar)	Fluid Temp (°C)	Amb Temp (°C)
From	1/4"	8	10	15	-10	-10
To	1/2"	14	20	40	75	50

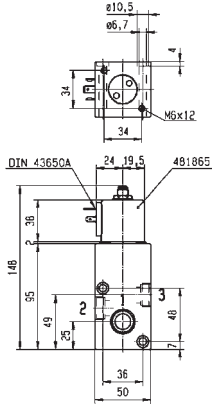

Weight: 0,96 ka

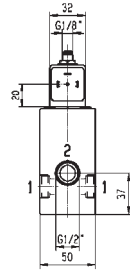

Drawing 3238

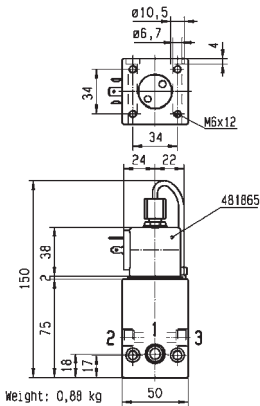

Weight: 0,88 kg

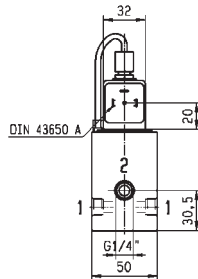

Drawing 8114

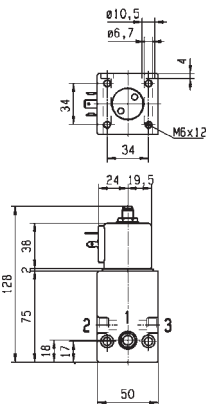

Weight: 0,88 ka

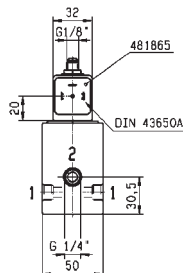

Drawing 3234

3/2

VALVES FOR DRY OR LUBRICATED AIR, NEUTRAL GASES AND LIQUIDS
PILOT OPERATED

ANODIZED ALUMINIUM PIPE MOUNTING

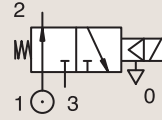

NORMALLY OPEN

Port size	Orifice Ø		Flow factor	Operating Pressure Differential			Fluid Temp.		Seat Seal	Parker LUCIFER® Valves			Power		Coil Group	Dwg. No.
	1	(2)		Min	Max (MOPD)		Min	Max		Valve Ref.	Housing Ref.	Coil Ref.	AC W	DC W		
BSP	mm		Qn l/min	bar	AC bar	DC bar	°C	°C								
1/2"	14	14	2500	1	15	15	-10	100	FKM	E332B21 ₁	2995	481865	8	9	2.1	3238
	14	14	2500	1	15	15	-10	100	FKM	E332B21 ₁	4270	481000	8	8	2.1	3238

Notes:

1. Valve only compatible with air and neutral gases

ANODIZED ALUMINIUM SUB-BASE MOUNTING

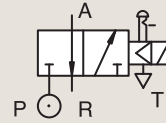

NORMALLY CLOSED

Port size	Orifice Ø		Flow factor	Operating Pressure Differential			Fluid Temp.		Seat Seal	Parker LUCIFER® Valves			Power		Coil Group	Dwg. No.
	1			Min	Max (MOPD)		Min	Max		Valve Ref.	Housing Ref.	Coil Ref.	AC W	DC W		
SB	mm		Qn l/min	bar	AC bar	DC bar	°C	°C								
SB	15		5000	0.5	10	10	-10	75	FKM	E331L21 ₁	2995	481865	8	9	2.1/3.0	3130
	15		5000	0.5	10	10	-10	75	FKM	E331L21 ₁	-	483371	8	8	2.1/3.0	3130

Notes:

1. With manual override



For this page	Port size	Orifice (mm)	Qn (l/min)	MOPD (bar)	Fluid Temp (°C)	Amb Temp (°C)
From	1/2"	14	-	10	-10	-10
To	1/2"	15	5000	15	100	50

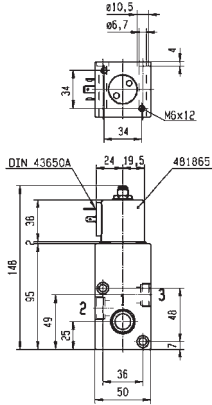

Weight: 0,98 ka

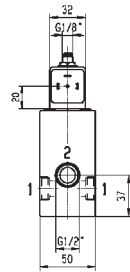

Drawing 3238

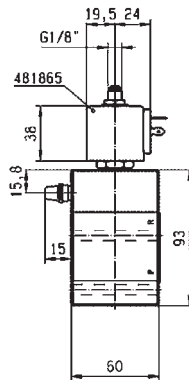
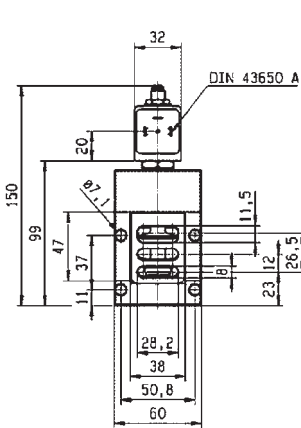

Drawing 3130